

LENGEND

	TREE TRUNK PROTECTION (2x4 TIMBER TRUNK PROTECTION) AND TREE ROOT PRUNE
	TREE PROTECTION FENCING (SNOW FENCE) TO LIMIT IMPACT ZONES
	CONSTRUCTION DISTURBANCE LIMITS
	TREE REMOVAL

NOTES:

- TREES TO RECEIVE TREE TRUNK PROTECTION AND TREE ROOT PRUNING ARE SHOWN ON THE TREE SCHEDULE ON THE FOLLOWING PAGE.
- TREE ROOT PRUNING SHALL FOLLOW THE INCLUDED SPECIFICATIONS AND SHALL OCCUR AT THE LIMITS OF THE AGGREGATE BASE COURSE OF THE PATH WHEN ROOT PRUNING IS NECESSARY.
- TREE PRUNING SHALL BE LIMITED TO THE MINIMUM EXTENT PRACTICABLE, BUT SHALL NEVER EXCEED MORE THAN EIGHT FEET FROM THE PATH CENTERLINE AND FIFTEEN FEET FROM THE GROUND.

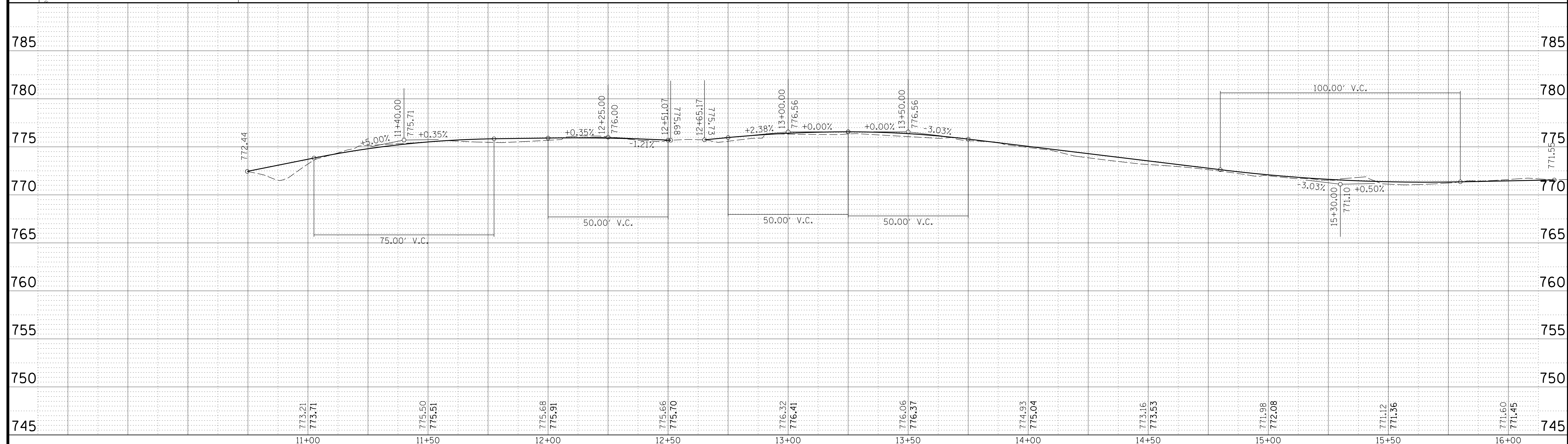
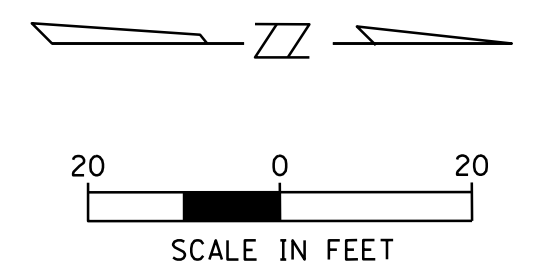

CHRISTOPHER B. BURKE ENGINEERING, LTD.
 9575 W. Higgins Road, Suite 600
 Rosemont, Illinois 60018
 (847) 823-0500



NO.	DATE	NATURE OF REVISION	CHKD.	MODEL:
FILE NAME	N:\Palatine\210024\Civil\TREE_210024_01.SHT			

TITLE: **PATH CONNECTION
 SMITH STREET TO JENS JENSEN FP
 TREE PROTECTION PLAN**

PROJ. NO. 210024
 DATE: 8/3/2021
 SHEET 1 OF 3
 DRAWING NO.
TREE 1

TREE MITIGATION TABLE

ID NUMBER	SPECIES	SIZE (IN)	CONDITION	COORDINATES	PROPOSED REMOVAL	PROTECT AND ROOT PRUNE	IN ZONE, BUT NOT PROTECTING
10	American elm	11	Good	1993523.5109,1061412.9001			
11	Black walnut	7	Very Good	1993534.9593,1061418.1463			
12	American elm	9	Fair	1993535.7721,1061428.8965			
13	American elm	14	Fair	1993540.8334,1061430.0052			
14	American elm	14	Fair	1993545.7688,1061425.7288			
15	Box elder	8	Fair	1993549.0830,1061421.7889			
16	Silver maple	50	Good	1993559.4321,1061419.2945		X	
17	Dead	NA	Dead	1993541.4438,1061419.0798			
18	American elm	8	Fair	1993542.1279,1061423.3916			
19	Dead	NA	Dead	1993537.1435,1061420.8672			
20	Silver maple	44	Fair	1993554.0373,1061453.1923		X	
21	American elm	6	Fair	1993551.4158,1061467.9024	X		
22	Silver maple	40	Good	1993558.5401,1061479.9137		X	
23	Buckthorn	6	Fair	1993569.1528,1061439.3091			
24	Buckthorn	6	Fair	1993569.0781,1061440.5612			
25	Silver maple	26	Good	1993580.1208,1061462.9735		X	
26	Buckthorn	6	Fair	1993587.3477,1061457.0537			
27	Buckthorn	6	Fair	1993589.5893,1061457.0760			
28	Buckthorn	6	Fair	1993597.9749,1061464.6157			X
29	Buckthorn	4	Fair	1993599.0014,1061460.2051			
30	Silver maple	25	Good	1993586.3926,1061486.0338		X	
31	Buckthorn	6	Fair	1993615.4837,1061450.6780			
32	Buckthorn	4	Fair	1993610.7027,1061443.0308			
33	Buckthorn	4	Fair	1993605.8741,1061441.4659			
34	Buckthorn	6	Fair	1993604.6178,1061439.9964			
35	Buckthorn	4	Fair	1993602.8271,1061438.7659			
36	Buckthorn	4	Fair	1993600.2114,1061438.3810			
37	Crabapple	13	Critical	1993624.3059,1061445.1136			
38	Dead	NA	Dead	1993620.6574,1061466.7125			
39	Buckthorn	4	Fair	1993633.8520,1061452.6731			
40	Buckthorn	4	Fair	1993634.8125,1061449.9016			
41	Buckthorn	4	Fair	1993636.0181,1061455.6312			
42	Buckthorn	4	Fair	1993637.4435,1061453.9466			
43	Buckthorn	4	Fair	1993638.3813,1061465.2303			
44	Buckthorn	7	Fair	1993640.0826,1061467.5890	X		
45	Sweetgum	15	Very Good	1993655.8226,1061490.7832		X	
46	Green Ash	15	Dead	1993820.4289,1061474.4447	X		
47	American elm	16	Good	1993818.2739,1061463.5265		X	
48	Honeylocust	30	Very Good	1993821.8165,1061445.8384		X	
49	No Tree						
50	Buckthorn	4	Fair	1993829.9911,1061460.7971	X		
51	Buckthorn	4	Fair	1993810.5725,1061474.4389	X		
52	Buckthorn	8	Fair	1993807.5104,1061476.8705	X		
53	Box elder	11	Poor	1993805.8211,1061479.2974		X	
54	Honeylocust	26	Very Good	1993723.8660,1061436.6222		X	
55	Honeylocust	28	Very Good	1993724.6645,1061461.0962		X	
56	Honeylocust	26	Very Good	1993712.6048,1061479.6798		X	
57	Black walnut	13	Very Good	1993717.6547,1061491.1093		X	
58	Siberian elm	9	Fair	1994049.4578,1061474.0011			
59	Siberian elm	9	Fair	1994030.2645,1061468.4601			
60	Dead	NA	Dead	1994027.2205,1061462.9810			
61	Buckthorn	6	Fair	1993986.3922,1061485.5122			
62	Dead	NA	Dead	1993984.8804,1061493.6573			
63	Black walnut	12	Good	1993975.7135,1061475.8603		X	
64	Cottonwood	28	Good	1994005.7942,1061435.8197		X	
65	Buckthorn	4	Fair	1994005.6497,1061439.7203			
66	Dead	NA	Dead	1993991.6431,1061426.7273			
67	Buckthorn	4	Fair	1993980.0191,1061420.5959			
68	Dead	NA	Dead	1993959.6374,1061423.3699			
69	Silver maple	60	Good	1993954.7211,1061454.0135		X	
70	Buckthorn	12	Fair	1993960.1587,1061483.8257			X
71	Buckthorn	4	Fair	1993947.5018,1061465.5120	X		
72	Dead	NA	Dead	1993915.3290,1061453.3175			
73	White ash	4	Fair	1993897.1247,1061479.4799	X		
74	Black walnut	8	Good	1993883.4582,1061482.5702		X	
75	Buckthorn	12	Fair	1993856.9367,1061482.8015			X
76	Buckthorn	5	Fair	1993841.9883,1061482.0638			X
77	Buckthorn	4	Fair	1993832.3751,1061483.4355			
78	White mulberry	4	Fair	1994069.2453,1061495.1403			
79	White mulberry	7	Fair	1993979.0640,1061499.1540			

TREE PROTECTION GENERAL NOTES

- Contractor is responsible for performance of and informing all staff and sub-contractors of tree protection requirements and penalties.
- Tree protection fencing, and other tree protection measures must remain in use during construction.
- All landscaping and mitigation activities within a Protection Zone must be done by hand to limit soil compaction. Mechanical equipment is prohibited within Protection Zone.
- Additional soil is prohibited within Protection Zone, unless approved by the Forest Preserve District of Cook County.
- Tree protection measures shall be in place and inspected by the Forest Preserve District of Cook County before any tree removal, stump removal, clearing, grading, demolition or construction work begins.
- All trees that may be impacted by work to be protected unless otherwise approved for removal.
- Contractor is responsible for compliance with the Tree Protection Plan, Mitigation Plan and standards outlined in the Tree Preservation Specifications Manual. Failure to comply with the standards, restrictions, conditions, and mitigation measures of the Tree Protection Plan, Mitigation Plans and Tree Preservation Specifications Manual may result in the issuance of a stop work order and may result in repair of damage and mitigation.

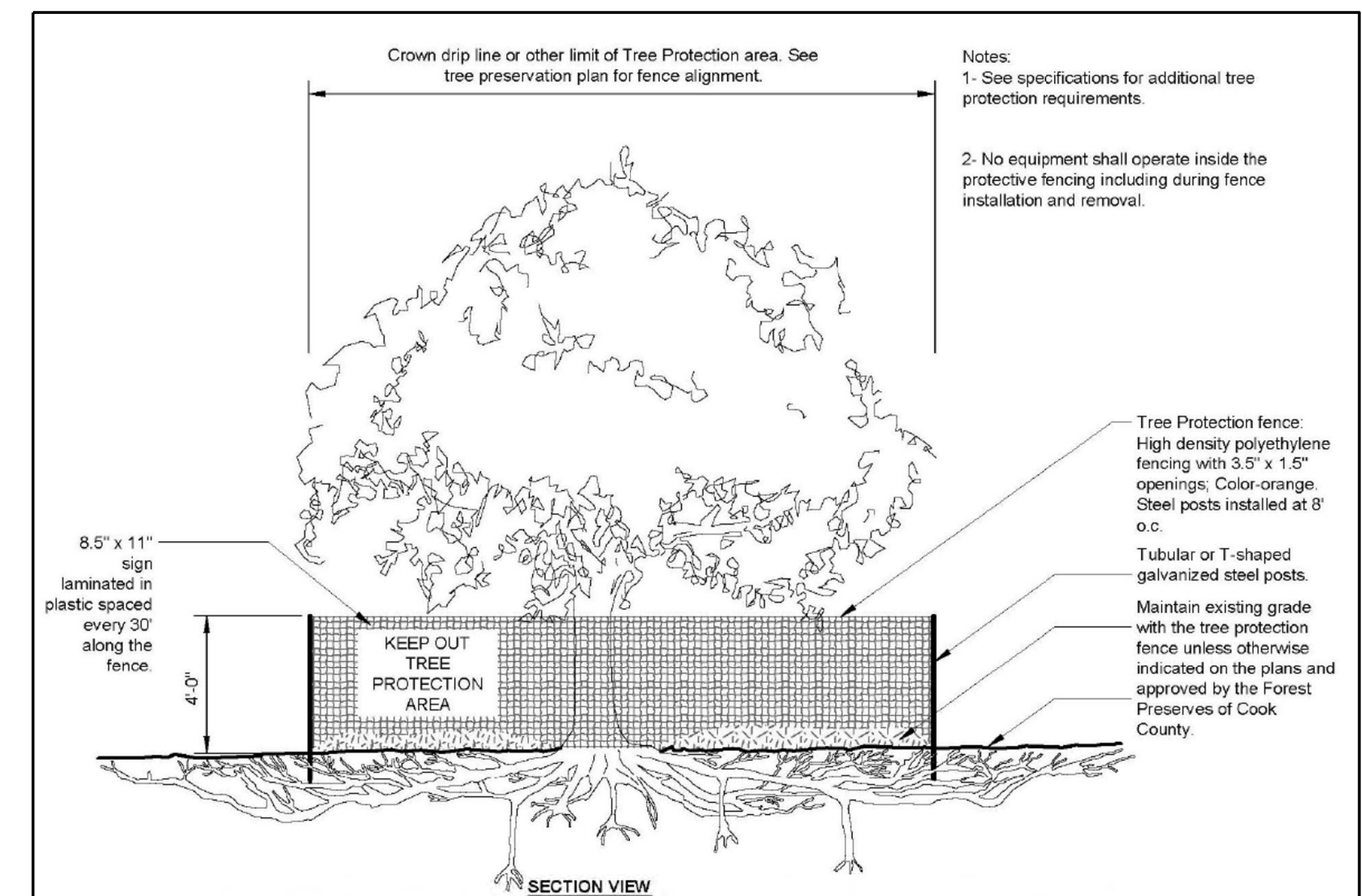

Figure 2: Tree Protection Fencing Detail (Source: Urban Tree Foundation - modified)

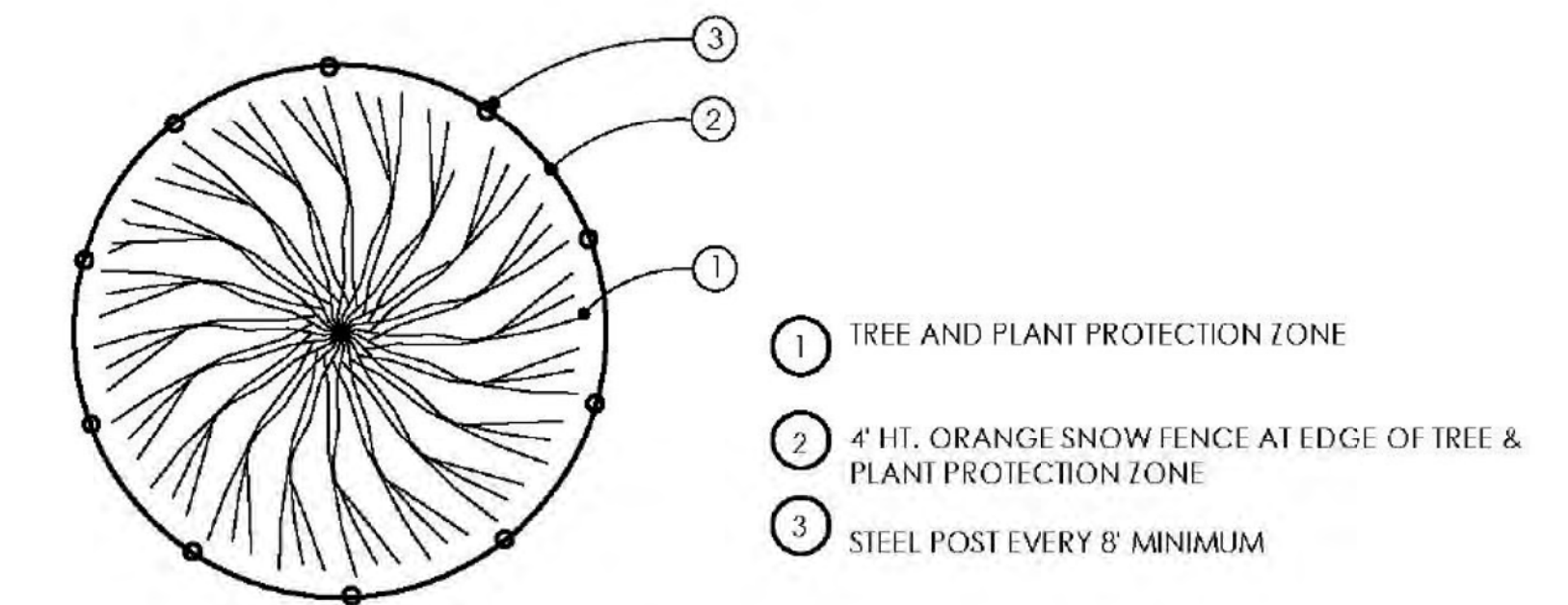
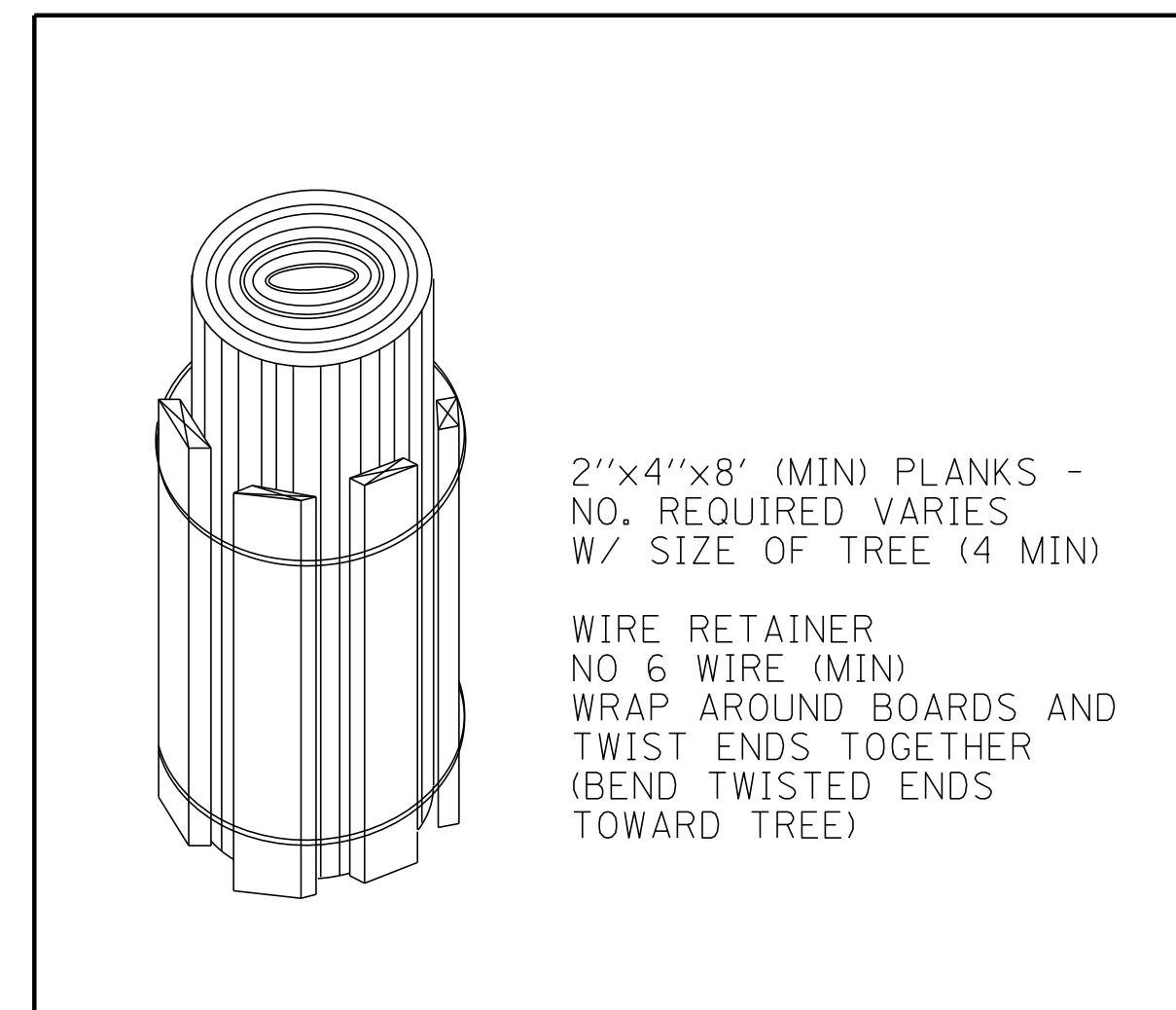

Figure 3: Tree Protection Fencing Detail - Plan View



TREE TRUNK PROTECTION DETAIL

TREE PROTECTION FENCING DETAIL

TREE PROTECTION SPECIFICATIONS

TREE ROOT PRUNING

This work shall consist of pruning the tree roots in accordance with Section 201 of the Standard Specifications, with the following modifications:

Description. If construction is to occur within the root zone of existing plant material, root pruning and special plant care will be required. All pruning shall be performed by a professional arborist.

Schedule. When possible, root pruning shall occur in the dormant season. Pruning of Oaks in the growing season is prohibited. Any pruning during the growing season shall require the cut surfaces to be painted with latex paint to prevent the spread of disease. Trees that are indicated for root pruning shall be irrigated prior to, during, and after root pruning.

Inspection. The site shall be inspected for visible aboveground hazards prior to beginning any root management procedure. The location of utilities and other obstructions both below and above ground shall be considered prior to root management operations. Utilities and other obstructions include but are not limited to: gas; electric; communications; sewer; drainage; and, irrigation. Conditions identified that would affect the operation, or are outside of, the scope of work should be reported to the project engineer.

Practices. Root pruning using an approved mechanical root pruning saw shall be performed prior to digging where noted on the plans or directed by the Engineer. Whenever roots of plant material to remain are exposed during construction, the damaged root ends are to be removed by cutting them off cleanly.

Roots should be cut with equipment that minimizes cracking the wood and tearing the bark. Root pruning tools shall be selected to meet the objective while minimizing damage to the plant. Wounds to the tree should not be covered, except to manage desiccation or pests. Cuts should result in a smooth surface whenever possible. When treating injured roots, only loose or damaged tissue should be removed.

Heavy equipment should be located outside the root cut line or remain on existing pavement or on a soil-protecting surface.

Temporary staging areas for excavated soil should be located at a safe distance on the side of the trench furthest from the trunk.

Process. Within the tree protection zone remove any sod, coarse woody debris or fresh mulch away from the root collar area. Select tools to avoid root and trunk damage. Repeat until trunk and flare are clear, out to the root collar, where buttress roots divide. Use smaller hand tools, vacuum, or compressed water or air, to complete the excavation for the area that is to be root pruned.

For root cuts on only one side of a tree, the root cut distance shall be no less three times the diameter at breast height.

Roots should be exposed using minimally damaging excavation method prior to pruning. The final cut should result in a flat surface with adjacent bark firmly attached.

Exposed fine roots (2mm or less) that due to the construction activities will remain exposed for periods longer than 24 hours shall be covered with burlap and repeatedly sprayed with water until the landscape restoration occurs.

When the construction process permits and within 24 hours that root pruning operation occurs backfill the root pruning trench with material excavated from the trench or loose screened topsoil and top with 3-4" shredded hardwood bark mulch.

Pruning shall be done in the presence of the Engineer and in such a manner as to preserve the natural growth habit of each plant.

Fertilizing and watering after root pruning shall be as follows.

1. Fertilizer Nutrients. Fertilizer nutrients shall be applied within 48 hours after root damage occurs. A three (3) month slow-release fertilizer with a 1:1:1 ratio shall be applied at the rate of 5 lb (2 kg) of nutrients per 1000 sq ft (90 sq m).

Application shall be accomplished by placing dry fertilizer in holes in the soil. The holes shall be 8 to 12 in. (200 to 300 mm) deep and spaced 2 ft (600 mm) apart in an area beginning 30 in. (750 mm) from the base of the plant. Holes shall be punched with a punch bar, dug with a spade, drilled with an auger, or any other method approved by the Engineer. Approximately 0.02 lb (10 g) of fertilizer nutrients shall be placed in each hole [250 holes/1000 sq ft (250 holes/90 sq m)].

If the Engineer determines that the hole method of fertilizer placement is not practical or desirable, an approved method of uniform surface application will be allowed.

2. Supplemental Watering. In case of inadequate rainfall, as determined by the Engineer, supplemental water shall be applied within 48 hours of any root damage. The water shall be applied at the rate of 2 gal/sq yd (9 L/sq m) of surface area within the root zone of plant material having sustained damage to the root zone. Subsequent weekly waterings shall be applied if deemed necessary by the Engineer.

The area within the tree protection zone shall be covered with a 2" layer of shredded hardwood bark mulch. This material will remain place until landscape restoration occurs.

Measurement and Payment. This work will be paid for at the contract price per EACH as

TREE ROOT PRUNING

which price shall be payment in full for all labor, material, and equipment necessary for the supply, and installation of the planting soil and all incidental work and materials herein specified.

This work shall consist of pruning the tree roots in accordance with Section 201 of the Standard Specifications, with the following modifications:

Care of Existing Plant Material.

(b) Tree Pruning. Tree pruning shall consist of pruning branches, for aesthetic and structural enhancement, of existing trees as shown on the plans or as directed by the Engineer. All pruning shall be done according to the current ANSI A300 (Part 1) – Pruning standard. All branch pruning shall be done between October 15 and April 15, when the trees are dormant.

When possible, pruning shall occur in the dormant season. Pruning of Oaks in the growing season is prohibited. Any pruning during the growing season shall require the cut surfaces to be painted with latex paint to prevent the spread of disease.



				DSGN.	
				DWN.	
				CHKD.	
				SCALE:	20'
				PLOT DATE:	8/5/2021
				CAD USER:	nmoriel
				MODEL:	Default
NO.	DATE	NATURE OF REVISION		CHKD.	MODEL:
FILE NAME	N:\Palatine\210024\Civil\TREE_210024_03.SHT				